

**7512F Series Bright ★ Pipes™ Flexpipe™ Fiber-Optic Lightpipe**

**DESCRIPTION AND FEATURES**

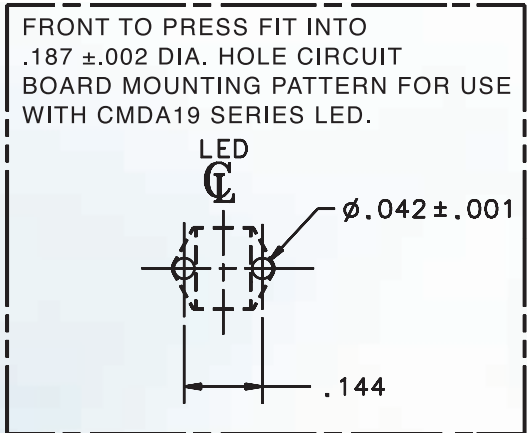
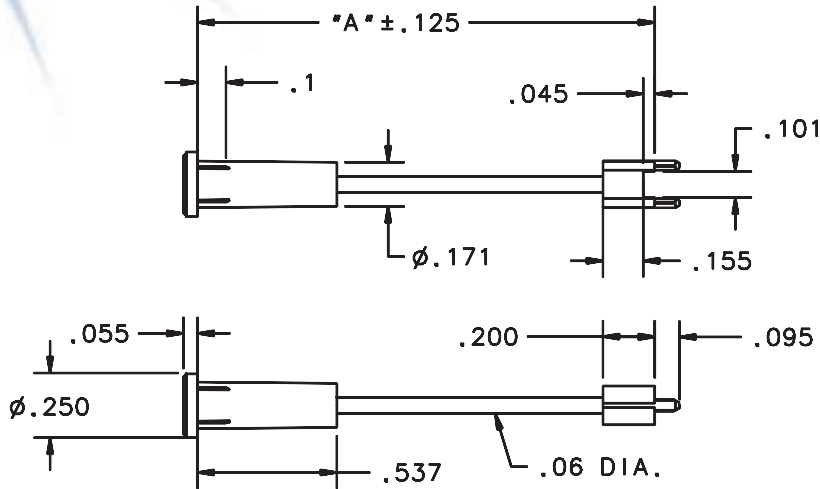

Series Number Dim A length (in mm)  
7512FPR- 305 (standard model)  
7512FPR- XXX\*

\*Note: • Standard model length is 305 mm.  
Product is available in lengths of 100 - 1800 mm  
in increments of 25 mm. Replace the XXX with  
the length of your choice.  
Minimum order quantities may apply,

- Flexible optical lightpipe with precision fiberoptics for long distance SMT LED to lens.
- Eliminates need for precision mechanical alignment of components to panel.
- 7512F is designed for use with CMDA19 series Bright Chip LEDs.
- Precision engineered with ray tracing for bright, optically precise even indication and attractive appearance.
- ESD protection from circuitry for exceptional reliability.
- High contrast and wide viewing angle for greater visibility.
- Parts inserted after reflow to permit LED pad inspection before assembly.
- Large lens provides high visibility.
- Water clear optics for variety of LED colors.